

nexus 2000/3000

FILTRATION system

GRAVITY FED

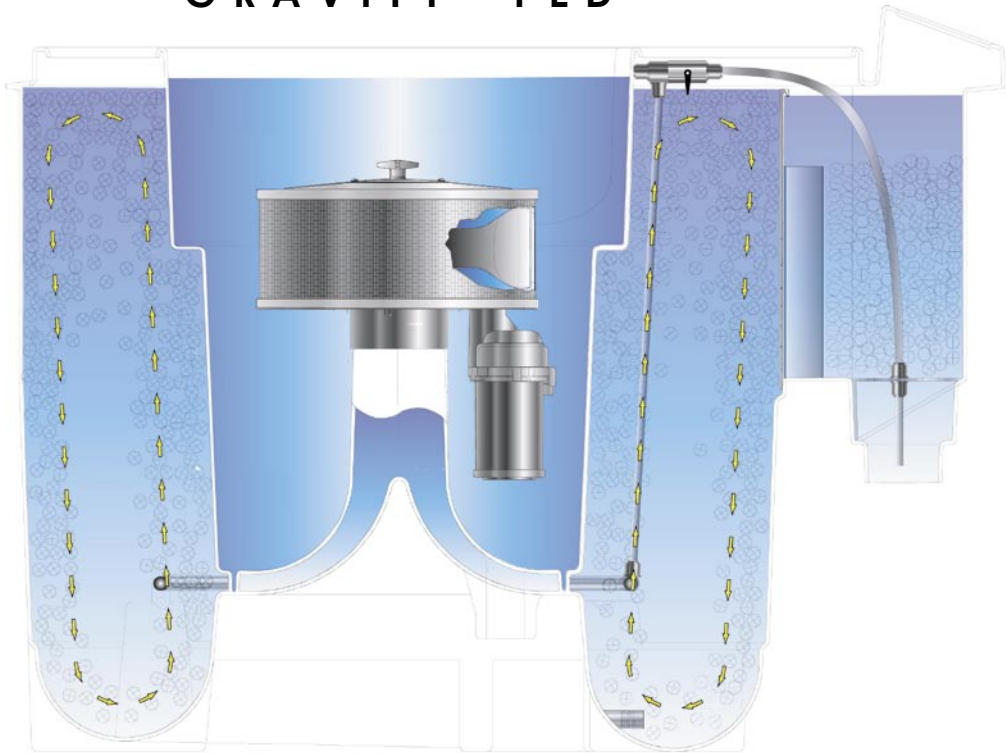

Installation & Operating Instructions

Note: Do not attempt to operate this unit before reading the manual thoroughly

Manufactured by Evolution Aqua Ltd.
Evolution House
Kellett Close
Wigan WN5 0LP
Tel: +44 (0) 1942 216554
Fax: +44 (0) 1942 216562
Web: www.evolutionaqua.com
E-mail: info@evolutionaqua.com



Thank you for purchasing the 'Nexus 300' Filtration System; we are sure you will be very pleased with its results.

You should have already decided whether your filter system will be pump or gravity fed. This product manual is ONLY FOR GRAVITY FED SYSTEMS.

It is important to read this installation manual thoroughly before attempting to position and install your Nexus 2000/3000 filter.

The 'Nexus 300' filtration unit has been designed on the principles of minimum maintenance, high performance and a compact footprint. This design delivers optimum water quality by using the Kaldnes Moving Bed™ process.

Basic Operation:

This section briefly explains the basic operation of the Nexus 300 Filtration System. Water is delivered to the inlet of the filter and enters chamber A (fig. 10). This chamber is the main mechanical stage of the filter. A Nexus 2000/3000 contains an Answer. The majority of solids and debris are stopped in chamber A and are sumped to waste via the 1.5" ball valve provided. The water then passes to chamber B containing the Kaldnes K1 media where the biological filtration takes place. The air ring at the base of chamber B constantly agitates the media. Chambers C and D remove final small particles before the water finally returns to the pond. This functions because a small quantity of K1 media is placed in the outlet chamber where it is unaffected by the air movement in chamber B, so it remains static. When static this media acts as a very efficient fine particle filter, which is simple to maintain incorporating the airbackwash system that is fitted.

Follow the relevant section carefully and your filter will perform correctly providing a perfect environment for your Koi.

Nexus 2000/3000 Specifications and Flow Rates

Follow your relevant section carefully and your filter will perform correctly providing a perfect environment for

your Koi. One of the factors that can have a significant influence on the general parameters of our ponds is turn over rate. This is the time that it takes for the total volume of the pond to pass through the filter system once. On Nexus ponds a turn over of every 2 to 3 hours is found to be best.

Nexus 2000

Max flow rate:	10,000 litres/hr 2,200 UK or 2,640 US gallons/hr
Max pond size:	18,000 litres 4,000 UK or 4,800 US gallons
Kaldnes K1:	50 litres (for bio stage – max 150 litres possible)
Volume of Water in Filter:	97 gallons, 440 Litres or 116 US gallons

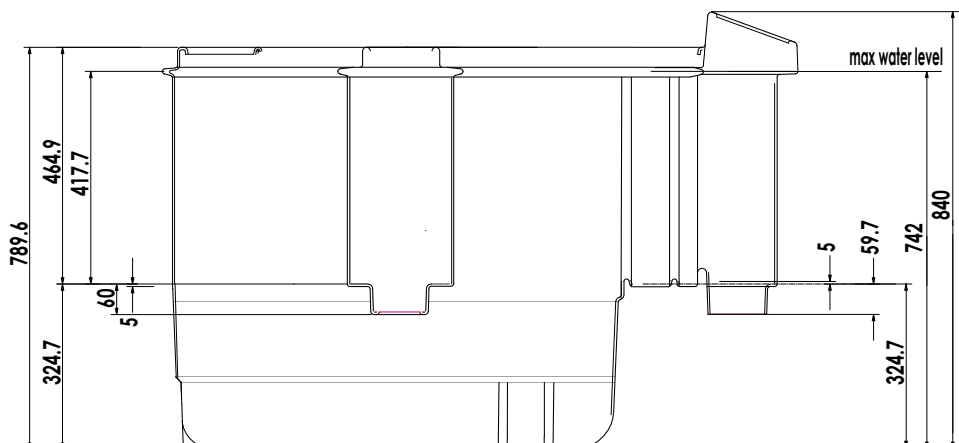
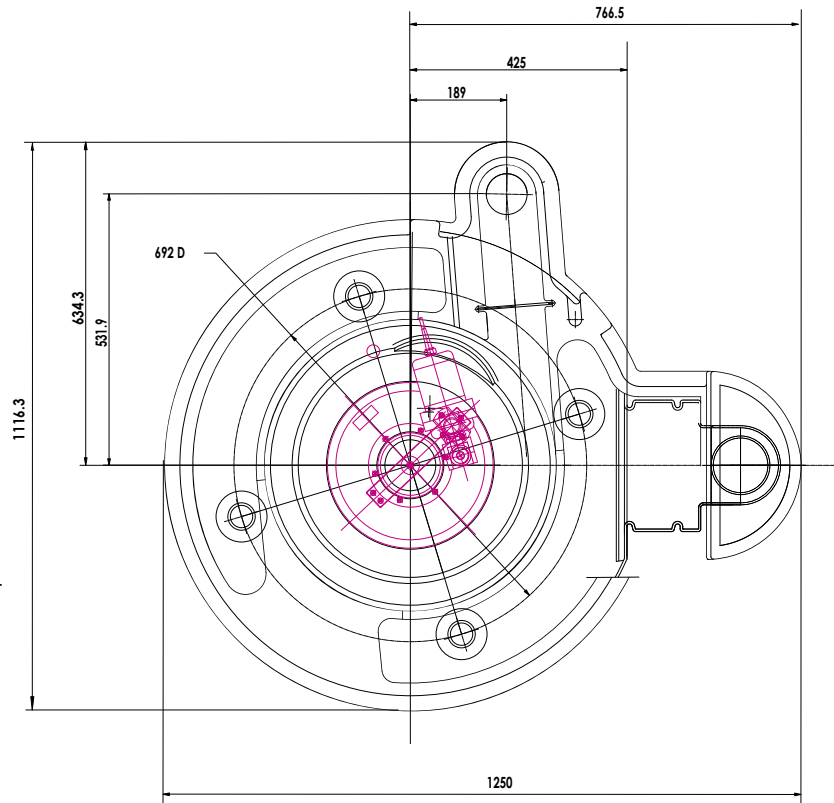

Nexus 3000

Max flow rate:	13,000 litres/hr 2,859 UK or 2,640 US gallons/hr
Max pond size:	18,000 litres 7,500 UK or 4,800 US gallons
Kaldnes K1:	100 litres (for bio stage – max 200 litres possible)
Volume of Water in Filter:	170 gallons, 772 litres or 204 US gallons

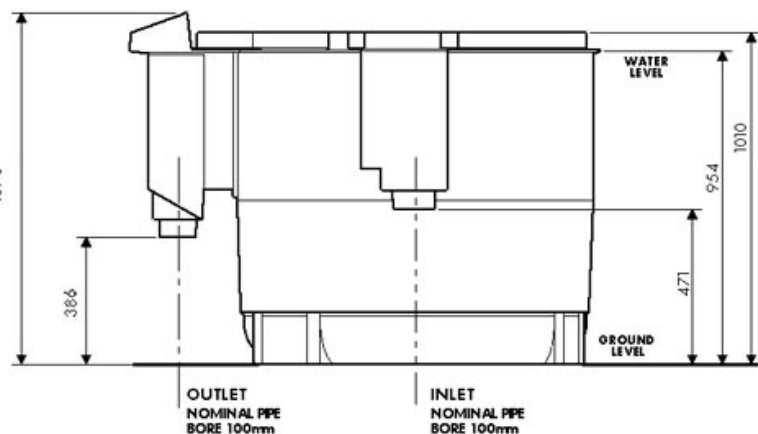
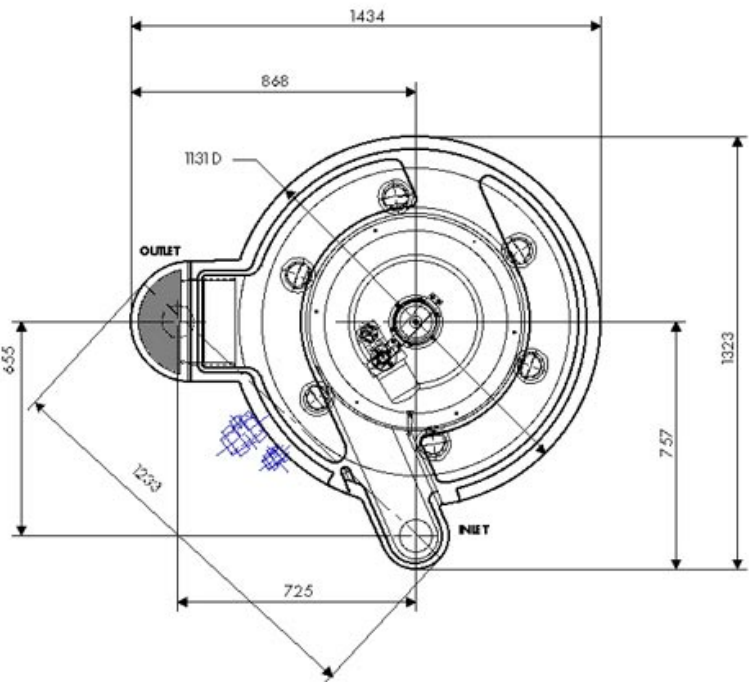

Fig. 1



Fig. 2

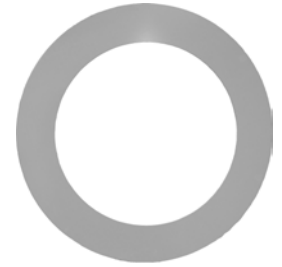

Fig. 3



Fig. 4



Fig. 5



Fig. 6

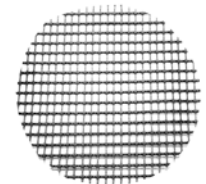

Fig. 7

Fig.5 Inlet plate.

Fig.6 Two rubber connecting adapters, fitted to the Nexus main body (fig. 1).

Fig.7 Security Mesh fitted with unit.

On opening your Nexus you will find the following;

- Fig.1 Nexus 2000 or 3000 main body
- Fig.2 Answer 325 (Nexus2000) or Answer 410 (Nexus 3000)
- Fig.3 Orifice Plate for Answer 325 or 410
- Fig.4 Kaldnes K1 for bio chamber Nexus 2000 = 50 litres Nexus 3000 = 100 litres.

Gravity Fed Systems

The Nexus filtration system can be used in two ways, gravity or pump fed (fig. 8 - Gravity). If you wish to install a pump fed system, please refer to the pump fed installation instructions.

INSTALLATION SECTION

Ensure that you read all the following installation sections.

- Preparation
- Installation Equipment
- Gravity Fed Installation Section

of this depends on the distance between the air pump and the Nexus.

6. **Ensure that the air pump is sited well above water level to prevent water siphoning back**

Fig. 8 - A Typical Gravity Fed System

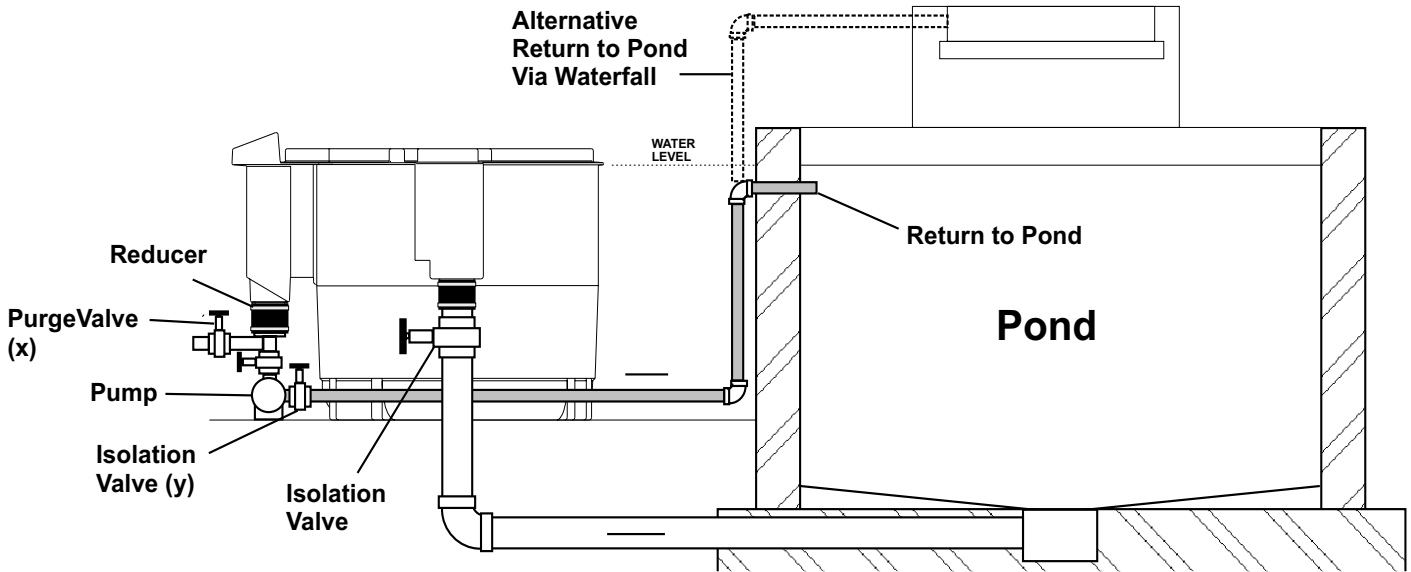

Preparation

A base of level solid ground is required. It should be a minimum of 1.2 m x 1.0 m, to allow easy access to valves and for maintenance purposes.

Important

The Nexus filter needs to be equally supported on the three pairs of feet which are located under the vessel. This is to prevent possible distortion when it is full of water.

The best option for this would be a level 100 mm thick concrete plinth. Although decking, paving slabs or gravel would be sufficient as long as the Nexus 300 sits level and is not allowed to deflect under the weight of the water. The upper surface of this base should be 954 mm below the proposed final pond surface water level (see fig. 7).

from the filter into the air pump due to power cuts or maintenance shut downs.

7. Pipe work from the unit's waste valves to the intended discharge point. This can be rigid pipe work or a simple flexible hose.
8. A PVC reducer to connect your circulating pump or pipe to the rubber connector supplied with your Nexus 200 (the size of which will depend on your choice of pipe work to and from the pond itself).
9. Care must be taken when connecting the waste valves to your chosen point of discharge because it will be below ground level. So you must ensure that the inner chamber of the Nexus will drain completely. An option is to fit a small solid handling pump on the waste water pipe work after the discharge valve.

Installation Equipment required or recommended:-

1. **A 110 mm / 4" or 75 mm / 3" ball or slide valve** on the inlet, to isolate the unit (optional).
2. **A T-piece assembly with 2 valves (fig. 11)** is required to isolate the unit from the circulating pump and to facilitate discharging to waste.
3. **Circulating Pump**, with a maximum actual flow rate that does not exceed your model's specification. The actual flow rate is dependent on the length and the amount of bends within the pipe work.
4. **Air pump** to power the Kaldnes K1 Moving Bed, see specifications for the size of pump required on page 6.
5. **Length of hose or braided pipe** (10 mm inner diameter) to connect the air pump to the already positioned / supplied air ring. The length

Gravity Fed Installation Section

Once you have positioned the Nexus, please connect the pipe work in accordance with your requirements.

Recommendations:-

The rubber 110 mm / 4" boot supplied will go onto the inlet point, connecting the Nexus to the pond after the recommended isolating valve has been fitted between the bottom drain and your Nexus.

The other rubber boot (supplied) will then fit onto the outlet side of the Nexus to connect the outlet to your circulating pump. A PVC adapter / reducer may be required.

To allow the correct maintenance procedure the following pipe work arrangement must be used. This arrangement is shown in figure 8 & 10.

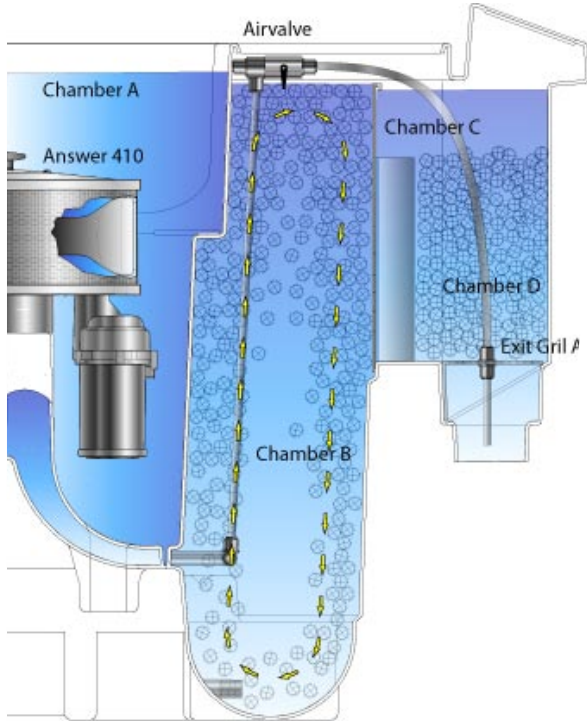

Fig. 9

One ball valve is fitted on the return line pipe between the Nexus and the pump. A T-piece must be fitted above this ball valve with some extra pipe where you can fit a second ball valve. This set up will allow the static media in Chambers C & D to be agitated for cleaning purposes whilst the pump return valve is closed (pump switched off) and the purge valve to waste is open. If using a heater or UV we suggest these are positioned after the circulating pump.



Fig. 10

Air Pump Installation

The size of air pump required will depend on the amount of K1 media used.

Air Pump Size	Capacity of K1 media
40 litres per min	100 litres of K1 media.
80 litres per min	100-150 litres of K1 media.
120 litres per min	150-200 litres of K1 media.

The air pump is connected using a pipe (10 mm inner diameter) to the air ring inlet which is positioned on the outside of the Nexus). It is recommended to position the air pump higher than the surface water level in the Nexus to prevent water flowing back into the air pump



Fig. 11

when it is switched off (see fig. 11).

'Answer' Installation

When installing 'the Answer', the rubber boot fitted to 'the Answer' has to be removed (see fig. 12).

Remove 'the Answer's' rubber boot with a screw driver (fig. 14) and carefully place 'the Answer' in the Nexus 300 with the pump located in the recess provided (fig 16). **The Answer will then push fit onto the black centre adapter (see fig. 12).**



Fig. 12

Orifice Plate Installation

In order to install an 'Answer' within the Nexus 2000/3000, you can fit either a 325 or a 410, Nexus 2000/3000 orifice plate. Fitting the orifice plate greatly enhances the Answer's performance by allowing settlement of debris to occur much more efficiently. Slot the orifice plate until it sits on the inside rim of chamber A (fig. 13). We recommend leaving the orifice plate unscrewed to enable you to remove it if you wish to clean the central chamber.



Fig. 13

Getting started.

When all the connections have been made the Nexus filter may be filled from the pond and the air pump switched on. The K1 media will not attain neutral buoyancy completely to begin with. Most of the media floats, which is normal. In existing mature pond water the media may start to circulate fully in as

little as 2 - 3 hours. In a newly filled and stocked pond this full movement may take up to a week to occur. Either way a constant and even circulation should be achieved throughout the chamber. (For more information about this please read the Kaldnes K1 media section).

During the initial stages before the media is circulating fully it will float on the surface of the water. It is inevitable that some media will escape from the biological stage (chamber B) back into central chamber A. This will not occur when the media has matured.

NEXUS 2000/3000 MAINTENANCE - GRAVITY FED

Daily Maintenance

In **high** feeding situations, the large waste valve may be opened daily for 15 seconds. This will remove the bulk of the waste from the centre chamber easily. This does not require switching off of the air pump or circulating pump etc.

NB: This does not replace the need for weekly maintenance below.

Weekly Maintenance

On the following pages are the recommended maintenance procedures for the Nexus 2000/3000 gravity fed system. Follow the maintenance procedure appropriate to your system configuration. We suggest that these are carried out weekly. The main benefit of using the Nexus means less maintenance is required, However this maintenance routine will vary from pond to pond, depending on stocking levels, blanket weed etc..

IMPORTANT:

PLEASE TURN OFF THE AIR PUMP BEFORE ANY WEEKLY MAINTENANCE IS UNDERTAKEN.

GRAVITY FED WEEKLY MAINTENANCE

Nexus 2000/3000, Gravity Fed with Answer

IMPORTANT FIRST STEP DURING CLEANING

To maintain the clarity of the pond it is VERY important that the static Kaldnes media in chambers C & D is ALWAYS cleaned BEFORE the central Answer chamber is discharged.

1. Turn off the circulation pump
2. Close valve 'Y' and open the T-purge valve 'X' (fig.10) and fully agitate the static media contained within chambers C & D by diverting the air from the biostage to the exit. This will dislodge all of the fine particles which have collected in the static Kaldnes media and as T-purge valve (X) is open all of this fine debris will pass straight to waste. Some of the media that was static in chambers C & D may pass back into chamber B whilst this process is taking place. This is normal. When the static media has been fully cleaned and the water runs clear (or for approximately 2 minutes), the T-purge valve (X) should be closed.



Fig. 14

- During the early stages after conversion the cleaning procedure may need to be carried out more frequently than normal. The intervals during cleaning will increase as the accumulated fine particles are removed.

- During periods of blanket weed or algal blooms, or during and following treatment for the removal of blanket weed the frequency of cleaning may also need to be more frequent to remove the rapidly decaying weed particles.

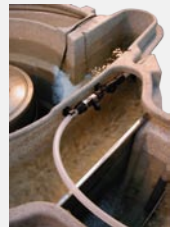

3. Turn off the air pump.
4. Insert slide plate into chamber A, to isolate the Nexus 300 from the pond (fig. 14).
5. Turn off the circulation pump.
6. Switch off Answer pump.
7. Open large waste valve.
8. Allow the inner chamber A to empty.
9. If required remove and clean the Answer screen (see Answer manual).
10. Remove the slide plate to purge bottom drain pipe work. This prevents build up of waste.
11. Once the water from the bottom drain line is running clear, carefully replace the slide plate, as the force of water may overflow the inlet weir.
12. Allow the inner chamber A to empty and hose out as required.
13. Close the large centre chamber A waste valve.
14. Remove the inlet slide plate.
15. Allow chambers A & B to refill, bleed the Answer as per the Answer manual.
16. Switch on the air pump.
17. Open the isolating valve (fig. 10 - Y) to the pump return.
18. Switch on the circulation pump.
19. Switch on the Answer.
20. Top up pond as required to correct pond level.
21. The static media will automatically re-pack itself into chambers C & D, where it will remain until the following weekly maintenance is performed.

Kaldnes Moving Bed™ Process

Kaldnes Moving Bed™ process, has been scientifically tried and tested in fish farming and waste treatment for over 10 years.

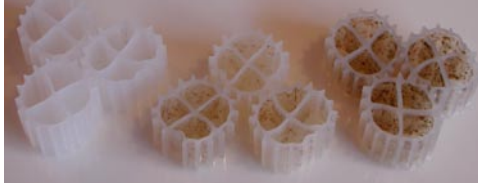

Illustrated above are the different stages of maturity that will be experienced during the first few months.

Developed by Professor Halvard Ødergard at Trondheim University of Science and Technology the Kaldnes Moving Bed™ bio film process has been designed specifically to create the most effective environment for the nitrification process to take place. The media is engineered in a wheel shape and is slightly positively buoyant, allowing a small amount of water flow (created by adding air to the process) to circulate the media throughout the vessel.

Oxygen and food (ammonia and nitrite) gives the bacteria the means to grow, whilst the Kaldnes media provides maximum surface area for the bacteria to colonise and produce bio film. It is this process, which removes harmful ammonia and nitrite from the water. As the Kaldnes media chaotically circulates within the bio tank, it causes old dead bacteria/bio film on the outside, to be removed making space for new younger heavier feeding bacteria/bio film to colonise. Within the wheel, is a protected surface, which enables colonies of bacteria to naturally follow their life cycle, maturing and dying, in turn fuelling the latter stages of nitrification conversion process. It also assists in the breakdown of any small particles passing through from the mechanical stage. Therefore, the Kaldnes media maintains both a young biofilm and a maturing bio film providing a more consistent filter performance, whilst improving water quality, encouraging healthier Koi and aiding in reducing green water and blanket weed. Due to chaotic movement of Kaldnes K1 media, the process is self-cleaning and requires no maintenance. This allows the filter to reach optimum effectiveness without the disturbance of periodic maintenance, avoiding unnecessary loss of bacteria within the filter preventing high levels of ammonia and nitrite within the water. The other major benefit of Kaldnes K1 media is the huge 'active' surface area available for the bacteria to grow on compared to other types of media. This feature allows for smaller filter design, e.g. the Nexus, whilst providing increased biological efficiency.

How it all works

Maturing the Kaldnes bio-media is important. The maturing process needs monitoring closely to ensure that levels of pH, ammonia and nitrite are within acceptable parameters for your fish. Usually, within 2 - 10 weeks the filter will be effective and the parameters should be within acceptable levels, depending on temperature and stocking levels.

Bacteria grows faster in warm water. E.g. a pond at 5 Celsius will have a very low bacteria count and a slow growth rate. Therefore temperature is important in reducing the time for a bacteria colony to develop.

Bacteria require food to live otherwise it will starve. The food for bacteria is liquid and solid waste produced by fish. Therefore higher stocking levels will provide more nutrients for the bacteria and help it to establish a colony. The liquid waste is called ammonia and is the food for the bacteria. Solid waste is broken down to ammonia, but a Koi keeper is better off removing the solid waste through settlement. The fitting of an Answer 325 filter into your Nexus 200 filter will improve this dramatically.

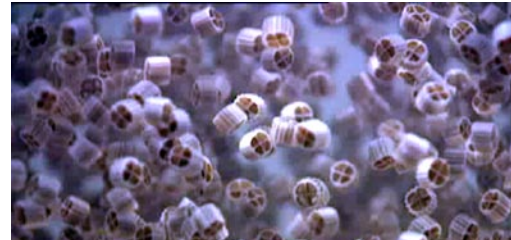

The ammonia reducing bacteria, nitroso-monas, produce an end product called nitrite, which is again potentially toxic to fish. This is controlled through establishing a large nitrobacter population to convert nitrite to the end product, nitrate. The effect of nitrate is less harmful than both ammonia and nitrite. However if nitrate levels are allowed to rise above 50 mg/L pond keepers may start to experience green water and blanket weed. The Kaldnes Moving Bed Process™ is very useful in controlling these levels as it has the highest removal rate of any submerged media on the market.

Nexus 2000/3000 Guarantee

This product comes with a 2 year warranty, which is valid from date of purchase. Proof of purchase will be required.

Any unauthorised repairs, modifications or alterations to this unit will invalidate the warranty.

Evolution Aqua accepts no responsibility or liability due to accident, improper installation or misuse. Liability is limited to replacement of the defective parts. This guarantee is not transferable. It does not affect your statutory rights.

If there is a warranty issue please contact Evolution Aqua's Technical Service department.

Claims for transport damage shall only be recognized if the damage is reported within 24 hours after delivery and confirmed by the carrier.

Evolution Aqua reserve the right to change this product specification without prior notice.

All products designed to ISO 9001 and manufactured to ISO 9000.



Distributed by:

Evolution Aqua Ltd
Evolution House, Kellett Close, Wigan, WN5 0LP
United Kingdom.

UK

Sales: +44 (0) 1942 219 898
Technical: +44 (0) 1942 219 872
e-mail: info@evolutionaqua.com
Web: www.evolutionaqua.com

Europe

Germany

Unique Koi

Rauhe Strausse 36, D46459 Rees,
Germany
Sales: +49 (0) 2851 58950
Fax: +49 (0) 2851 589525
e-mail: info@uniquekoi.de
Web: www.uniquekoi.de
e-mail: infodeutschland@evolutionaqua.com

Benelux, France, Spain and Italy

Smulders BV

Postbus 1022, 6235 ZG Ulestraten,
Netherlands
Sales: +31 (0) 43 3642387
Fax: +31 (0) 43 3509350
e-mail: info@smulders.nl
Web: www.smulders.nl
e-mail: infobenelux@evolutionaqua.com

USA & Canada

Pond Wise Inc.

429 Shields Rd, Huntsville, Alabama,
35811 USA
Sales: +1 (0) 256 859 0123
Fax: +1 (0) 256 859 0110
e-mail: pondwise@hiwaay.net
Web: www.pondwise.com
e-mail: infousa@evolutionaqua.com

Australia

Aussie Koi

PO BOX 663, Bulimba 4171, Queensland
Australia
Sales: +61 (0) 417 601 651
Fax: +61 (0) 7 3399 8892
e-mail: tim@aussiekoi.com
Web: www.aussiekoi.com
e-mail: infoasia@evolutionaqua.com

Asia

Max Koi Farm

251 Neo Tiew Crescent, Singapore 7
Singapore
Sales: +65 (0) 6862 6363
Fax: +65 (0) 6862 6262
e-mail: info@maxkoi.com.sg
Web: www.maxkoi.com.sg
e-mail: infoasia@evolutionaqua.com

South Africa

Cape Koi Aquarium

PO BOX 1312, Brackenfell 7561,
South Africa
Sales: +27 (0) 219889724
Fax: +27 (0) 219889595
e-mail: wiliam@whr.co.za
Web:
e-mail: infosouthafrica@evolutionaqua.com